



## QuickChange™ Adjustable Spring Plate kit - Instructions

Part Number 2080902

### Cars applicable:

'69-'86 911/912/930

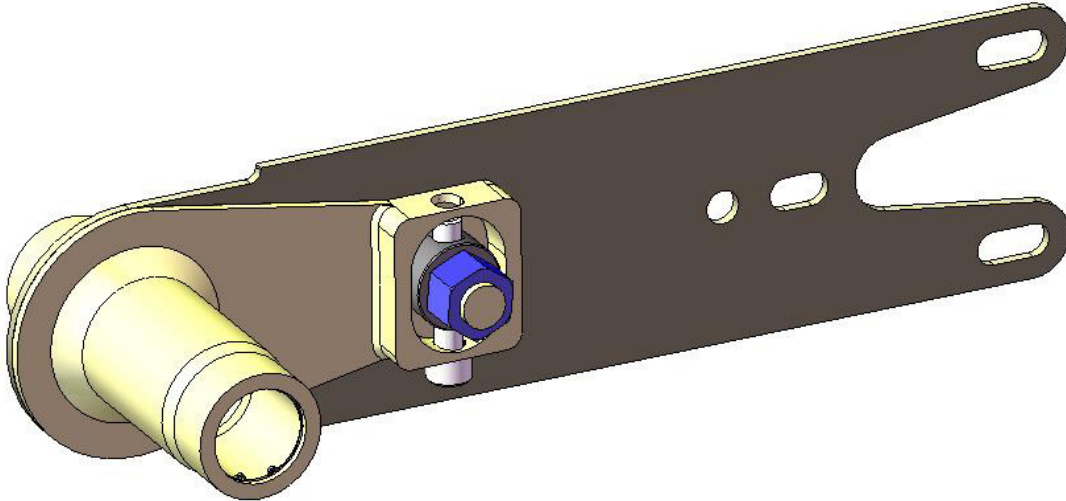

Figure 1 – Driver side QuickChange Spring Plate assembly

### Contents:

Two QuickChange Spring Plate assemblies, one driver side, one passenger side.

### Required and not included:

Spring plate bushings. While any bushing designed for factory spring plates may be used, PolyBronze™ spring plate bearings are highly recommended. Polybronze spring plate bearings are required if you wish take advantage of the torsion bar extraction features.

Toe and Camber adjusting hardware, use the factory parts. You can also use the CamberMax™ from Elephant Racing.

### Tools Required:

- 8mm hex key (allen head wrench)
- 17mm socket
- 19mm socket
- 24mm socket
- Snap ring pliers (for QuickChange Torsion Bar removal only)
- 3/8" 16tpi x 6 bolt (for QuickChange Torsion Bar removal only)

### Introduction:

Congratulations on your purchase of the QuickChange Spring Plate from Elephant Racing!

Used in combination with Elephant Racing QuickChange Torsion Bars your new QuickChange Spring Plates allow fast torsion bar replacement. You may use conventional torsion bars but they have no provision for easy extraction.

Other QuickChange Spring Plate benefits:

- Easy height and corner balance adjustment using a screw-type height adjuster
- Extra long bolt holes to afford a broad range of camber adjustment
- Bolted together for silent and reliable operation
- Compatible with Elephant Racing CamberMax for easy camber adjustment

Following installation of the QuickChange Spring Plate, a corner balance and alignment must be performed.

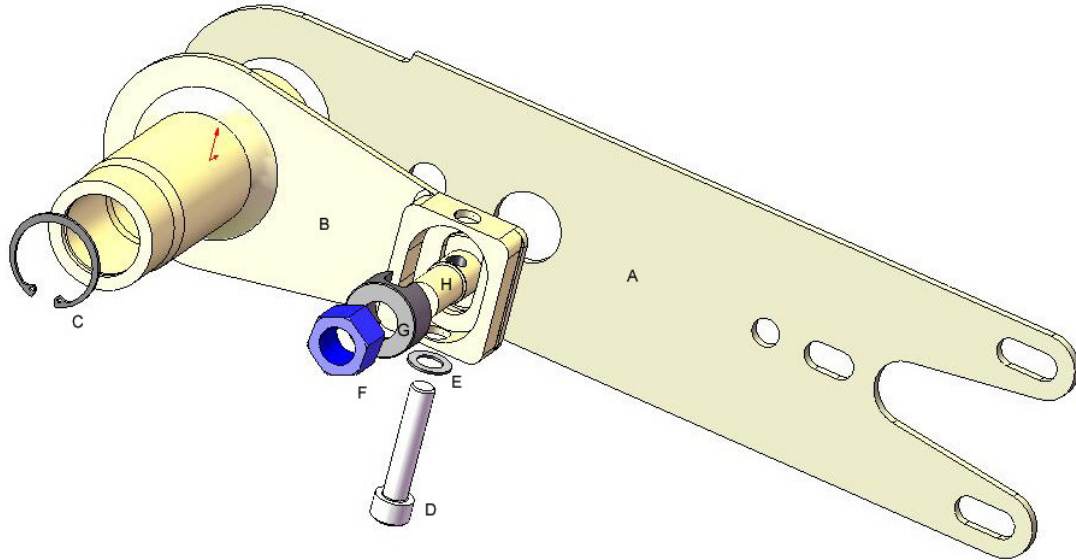

Figure 2 - Driver side QuickChange Spring Plate exploded view

Item #	Description	Torque
A	Blade	
B	Splined Hub	
C	Retaining Ring	
D	Height adjuster screw - M10 x 50 socket head cap screw	35 ft/lbs
E	Height adjuster lock washer - M10 belleville lock washer	
F	Clamping nut - M16 lock nut	115 ft/lbs
G	Clamping Spacer	
H	Clamping bolt	

**Installation:**

Installation requires the same procedure used for factory spring plates. Refer to your shop manual for details.

Refer to Figure 2. Note that driver and passenger side assemblies have opposing orientation of Height adjuster screw [D]. Install the assemblies such that the Height adjuster screw [D] is oriented as shown (head pointed down).

**Height adjustment / corner balance:**

**Caution: Height adjustment should only be performed with the car raised, tires off the ground, and no load on the suspension.**

Refer to Figure 2. The Height adjuster screw [D] affords about 2 inches of adjustment range and is used for fine adjustment. Coarse height is established with the spline position on the torsion bar. In the event that you reach the end of Height adjuster screw [D] range, you will need to re-index the torsion bars. Refer to the sections below on torsion bar replacement / re-indexing.

Use a 24mm socket to loosen the Clamping nut [F]. Use an 8mm hex key to rotate Height adjuster screw [D], tighten to raise ride height, loosen to lower ride height. Once you are satisfied with the height, torque the Clamping nut [F] to 115 ft/lbs. Finally, torque the Height adjusting screw [D] to 35 ft/lbs.

Corner weights should be checked and adjusted using appropriate scales anytime the ride height is altered.

**Torsion Bar replacement / re-indexing with QuickChange Torsion Bars:**

QuickChange Spring Plates facilitate rapid torsion bar replacement when used with Elephant Racing QuickChange Torsion Bars. QuickChange Torsion Bars have a threaded end that allows a regular 3/8" 16tpi bolt to be used as a handle for easy extraction / insertion.

Note: The ability to replace and re-index torsion bars only works when paired with PolyBronze suspension bearings.

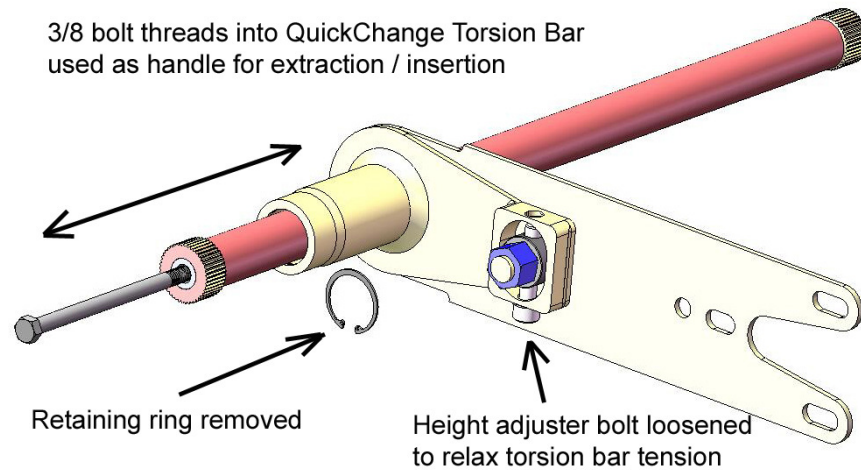

Figure 3 – Torsion bar replacement using QuickChange Torsion Bars

Refer to Figures 2 and 3. Jack up the corner of the car until the tire comes off the ground. Use a 24mm socket to loosen the Clamping nut [F]. Use snap ring pliers to remove Retaining ring [C]. Use an 8mm hex key to loosen the Height adjuster screw [D] and back it out about 6mm. Thread a long 3/8" 16tpi bolt into the QuickChange Torsion Bar to act as a handle. Pull the bolt to extract the torsion bar.

If the torsion bar resists: As the suspension compresses through its range of motion, the camber angle is changing – this twists the spring plate and creates tension on the splines that resists torsion bar extraction. With the clamping nut [F] loosened, slowly raise the suspension while continuing to pull on the torsion bar. You are seeking the point in the suspension travel (camber curve) that relaxes the twist on the spring plate. The torsion bar should then extract easily.

If the torsion bar remains stuck, fashion a puller tool using a length of pipe, a large washer, and the 3/8" bolt. Slide the pipe around the spring plate, cover the end with the washer, thread the bolt through the washer. Tighten the bolt to draw the torsion bar out.

If you are re-indexing the bar, rotate the bar and reposition Splined hub [B] to the desired angle.

Re-insert bar using the 3/8" bolt as a handle. Do not use force. When properly aligned the splines will slip together with minor effort. The outer splines will engage first followed by the inner splines. Typically you will need to oscillate the Splined hub [B] slightly to get the splines to engage. Finesse, not force, will get the job done.

Use snap ring pliers to replace the Retaining ring [C].

Re-adjust ride height as above. If you restore the original ride height your alignment settings will not change. However your corner weights will change and should be checked / adjusted after torsion bar replacement.

**Torsion Bar replacement / re-indexing with conventional torsion bars:**

Conventional torsion bars can be used, however they have no provision to grip the bar for extraction. When using conventional torsion bars, follow the factory procedures for replacement or re-indexing. Refer to your shop manual.

After replacement, re-adjust ride height as above. If you restore ride height to the same level, your alignment settings will not change. However your corner weights will change and should be checked / adjusted after torsion bar replacement.

**Camber and Toe adjustment:**

Re-use the factory camber and toe adjustment hardware. Refer to your shop manual for adjustment details. Alternatively you may use the Elephant Racing CamberMax™ for camber adjustment.



### Related Products available from Elephant Racing:

#### QuickChange™ Torsion Bars

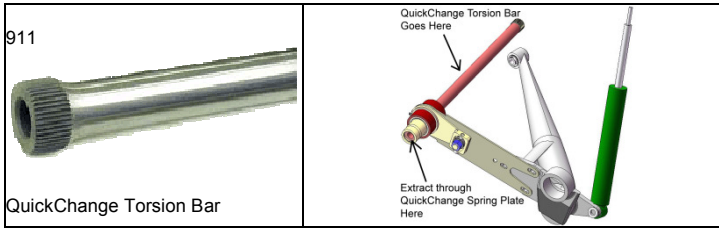

Hollow Torsion Bars with a threaded end for easy extraction and installation. A 3/8" bolt engages the threads to pull the bar out of the car. Use with our QuickChange Spring Plate products for easy 5 minute torsion bar changes.

#### PolyBronze™ Suspension Bearings

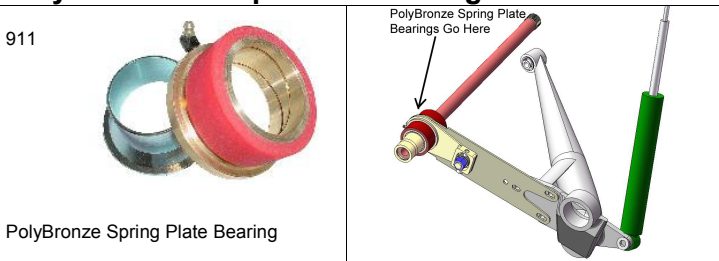

PolyBronze suspension bearings are a high-performance bushing replacement delivering precise handling AND a smooth ride. Easily installed, PolyBronze never squeaks.

The bronze bearing rides on a steel race for very-low friction allowing the suspension to do its job instead of fighting the bushings. You get a smooth ride and maximum grip.

An outer jacket of polyurethane absorbs any mount irregularities without interfering with the friction surface. Grease fittings allow easy re-lubrication – even to inner spring plate bearings!

Suitable for street or track, PolyBronze bearings do not deform under load. They maintain alignment settings for maximum grip.

#### Rear CamberMax™

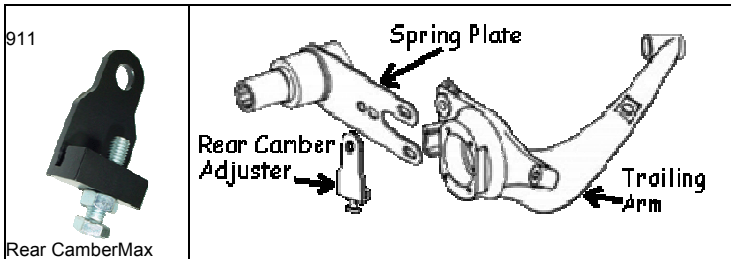

Rear CamberMax kit simplifies 911 rear camber adjustment, allowing aggressive negative camber settings of 3+ degrees. Instead of using the troublesome factory eccentric bolt, Rear CamberMax allows adjustment with a simple and precise screw.

Allows adjustment with vehicle weight resting on the tires making it easy to read a camber gauge while turning the adjuster.

#### Spring Plate Hardware Kit



While replacing spring plates, you'll often find that the hardware is worn and ready for replacement. We've assembled this kit as per factory specifications so you don't have to hunt and source the parts yourself